

### CABLE MANAGEMENT KIT ASSEMBLY

Model CM-F-1-ID or -MC

1. At the base of the robot (Zone D), begin by installing the base bracket (1) using the M8-1.25 x 16 mm bolts and M8 flat washers provided.
2. Attach the J1 Bracket (1) in Zone C to the robot with the M10-1.5 x 20 mm SHCS bolts and washers provided.
3. Attach the J2 Bracket (1) in Zone B to the robot with the M10-1.5 x 20 mm SHCS bolts and washers provided.
4. Attach the J3 Bracket (1) in Zone A to the robot with the M10-1.5 x 20 mm SHCS bolts and washers provided.
5. Insert cable hose into the preinstalled clamp blocks on each of the brackets. Install the top half of the clamp blocks to secure the hose in place. Tighten mounting bolts in place to bring clamp blocks together.
6. Attach the power cable lug to the connection point on the wire feeder using the M12-1.75 nylock nut and the copper PowerBall® washer.
7. Attach the other end of the cable to the positive power cable connection point at the base of the robot (Zone D). The second PowerBall® washer is used at this connection point.

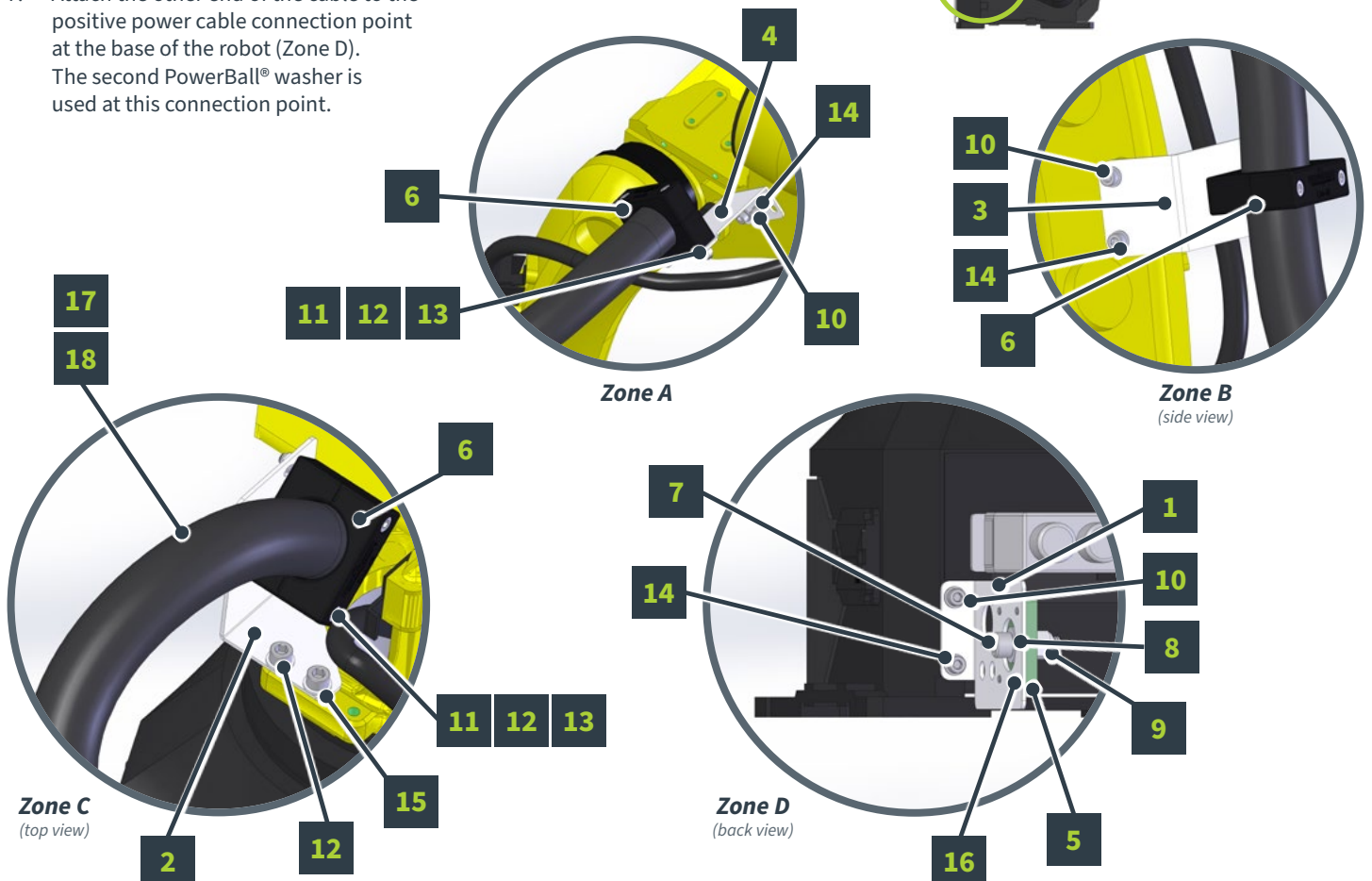

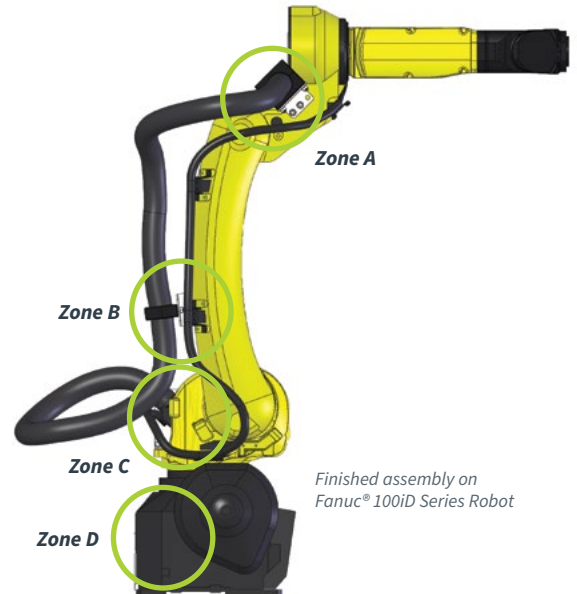

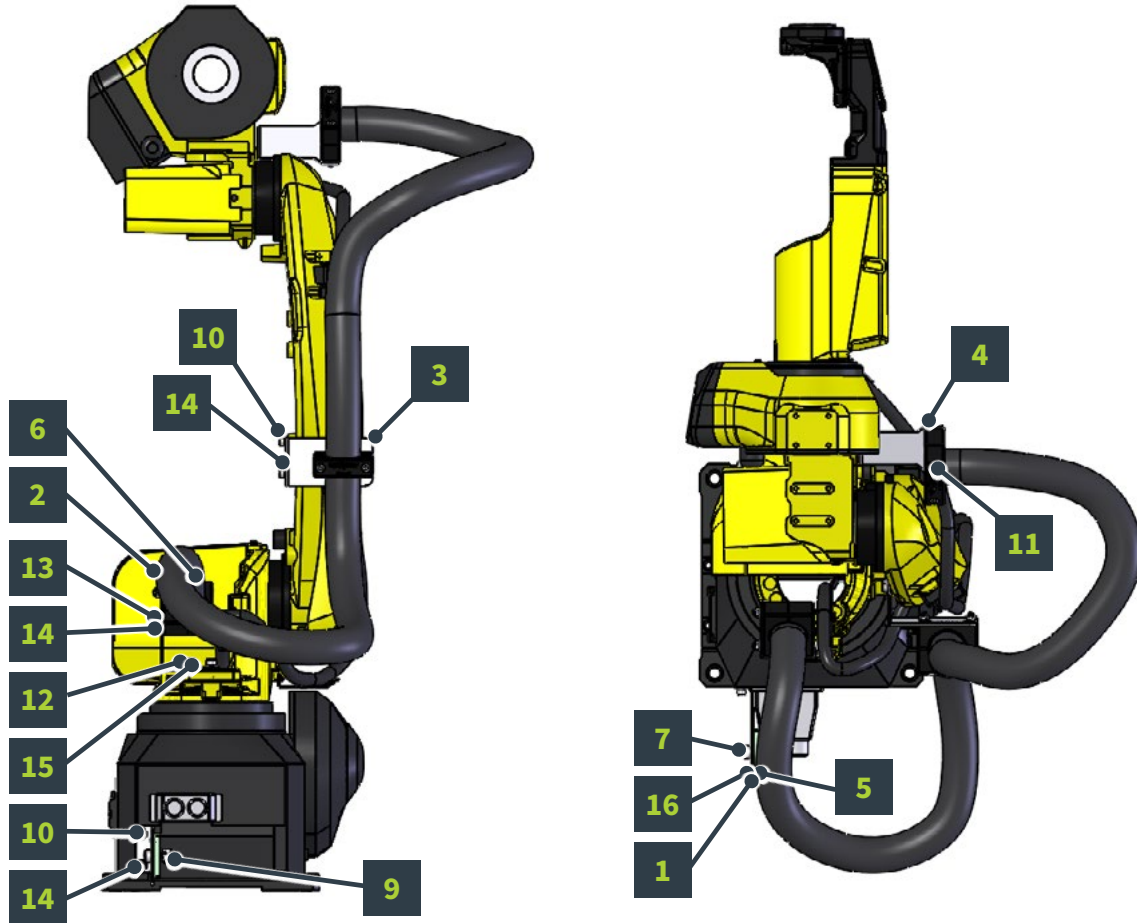





# PARTS LIST



Zone	Item No.	Part No.	Description	Quantity
D	1	CM-F-ID-2	Base Bracket	1
A	2	CM-F-ID-7	J1 Bracket	1
B	3	CM-F-ID-4	J2 Arm Bracket	1
A	4	CM-F-ID-5	J3 Bracket	1
D	5	CM-F-3-4-2	Base Insulator Plate	1
C, B	6	ASSY CM-48	Conduit Holder	3
D	7	35969	M12-1.75 x 35 mm SHCS (zinc plated)	1
D	8	33086	M12 Flat Washer	1
D	9	40171	M12-1.75 Nylock Nut (zinc plated)	1
A, D	10	35932	M8-1.25 x 16 mm	4
A, B, C	11	39614	M8-1.25 x 85 mm SHCS	6
C	12	103256	M10-1.5 x 20 SHCS	2
A, B, C	13	40163	M8 Nylock Insert Lock Nut	6
A, B, C	14	40357	M8 Flat Washer	16
C	15	40358	10 mm Flat Washer (zinc plated)	2
D	16	41389	M6 x 14 FHCS	4
A, B, C, D	17	PBC-3/0-8-L4	3/0 Welding Cable 600 V, Flat/60° Lugs	8 ½'
A, B, C, D	18	CM-FT-48-1	Continuous Flex Conduit	5 ½'
A, D	Not Shown	PBC-W-1	Copper PowerBall® Washer	1

## CABLE MANAGEMENT KIT COMPONENT PARTS LIST FOR CM-F-1-ID OR -MC

Image	Part No.	Description	Quantity
	35969	M12-1.75 x 35 mm SHCS (zinc plated)	1
	40171	M12-1.75 Nylock Nut (zinc plated)	1
	PBC-W-1	Copper PowerBall® Washer	1
		CM-F-1-ID-MC	0
	33086	1/2" Flat Washer (zinc plated)	1
	35932	M8-1.25 x 40 FHCS (zinc plated)	4
	103256	M10-1.5 x 20 SHCS (zinc plated)	2
	40357	M8 Flat Washer (zinc plated)	10
	40358	10 mm Flat Washer (zinc plated)	2
	35936	M8-1.25 x 25 SHCS (zinc plated)	2

**FILLED BY:** \_\_\_\_\_

**VERIFIED BY:** \_\_\_\_\_

